



# DRAGON

## RANCO Steel Mini Bottom Dump Trailer



### SPECIFICATIONS:

- Capacity: 24 cubic yards (approx.)
- Weight: 13,600lbs. (approx.)
- Axles: 5" diameter with oil seals, 22,500lbs. capacity, 71.5" track
- Brakes: ABS braking system, 16.5"x7" S-cam type, auto slack adjusters
- Wheels: 11 x 22.5 or 11 x 24.5 steel disc
- Electrical: DOT approved 12 volt sealed lighting system
- Plumbing: DOT approved system



[tanktrailer.sales@modernusa.com](mailto:tanktrailer.sales@modernusa.com) • [www.dragonproductsltd.com](http://www.dragonproductsltd.com) • 877-231-8198

U.S. owned and operated for over 50 years. © Copyright 2014 Modern Group Inc. All rights reserved.

# RANCO Steel Mini Bottom Dump Trailer

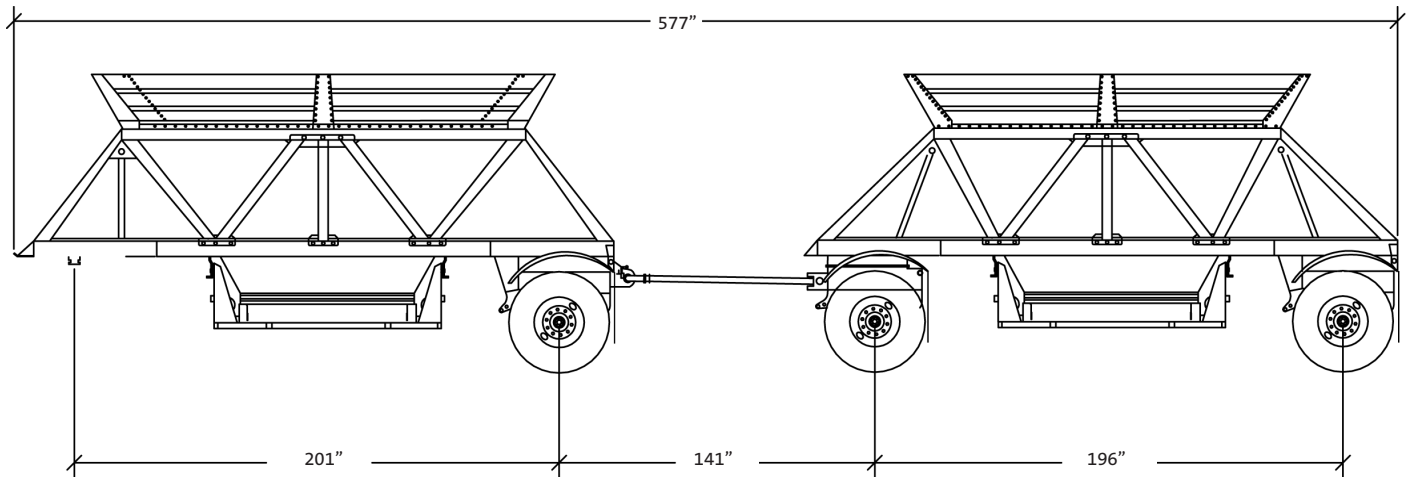

## SPECIFICATIONS:

- Capacity: 24 cubic yards (approx.)
- Weight: 13,600lbs. (approx.)
- Paint: Polyurethane
- Gates: Windrow Type;  
Gate end 10 gauge Hi-tensile,  
Gate bottom 10 gauge Hi-tensile  
with 4"x4" reinforcement Twin  
composite barrel air cylinder  
actuators, Adjustable chains front and rear
- Skins: 12 gauge Hi-tensile steel
- Shedplates: 14 gauge steel, welded on
- Bang Boards: 2"x10" wood bolted on
- Turnable Fenders: Steel weld on
- Gate controls: Versa Valve on left,  
electrically actuated from truck cab
- Gate hoses: Hoses are 1/2"  
with one quick release valve per cylinder
- Gate seals: Steel welded on exterior of gates
- Electrical: DOT approved 12 volt  
sealed lighting system
- Plumbing: DOT approved system
- Under Mount: Three leaf springs,  
36" German turntable double bearing
- Axles: 5" diameter with oil seals,  
22,500lbs. capacity, 71.5" track, hub piloted
- Drums: Centrifuge outboard drums
- Brakes: ABS braking system,  
16.5"x7" S-cam type, auto slack adjusters
- Drawbar: 87" long, square tubing,  
cast steel hinged bracket, rubber bused,  
2.375" ID swivel type eyebolt with safety cable
- Wheels: 11 x 22.5 or 11 x 24.5 steel disc



[tanktrailer.sales@modernusa.com](mailto:tanktrailer.sales@modernusa.com) • [www.dragonproductsltd.com](http://www.dragonproductsltd.com) • 877-231-8198

U.S. owned and operated for over 50 years. © Copyright 2014 Modern Group Inc. All rights reserved.