



DRAGON

Sand Delivery System Pneumatic Roll-off Pod



- Description: Portable Bulk Transport
- Type: aluminum barrel on roll off skid
- Capacity: Approx 800 cubic feet; depending on product
- Length: 264" O.A.I.; 224" Can head seam
- Barrel: 1/4" aluminum shell with 3/8" head 96" diameter
- Roll off: steel skid for standard roll off hoist
- Manways: 3- cam over latch
- Welds: internal - as welded, external, discoloration removed.
- Walkway: passenger side with handrail
- Air supply: 3" line road side with 1" to side and top of vessel.
- Pneumatic 4" center bottom unload line "y" connected to jet air supply.
- Fluidizer: cloth fluidizer pad full length at bottom for
- Pneumatic unloading system uses standard U.S. values, gauges, safety relief system.



tanktrailer.sales@modernusa.com • www.dragonproductsltd.com • 877-231-8198

U.S. owned and operated for over 50 years. © Copyright 2017 Modern Group Inc. All rights reserved.

Sand Delivery System Pneumatic Roll-off Pod



Patent Pending: 15/449,270

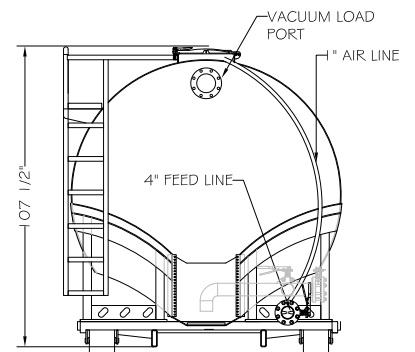
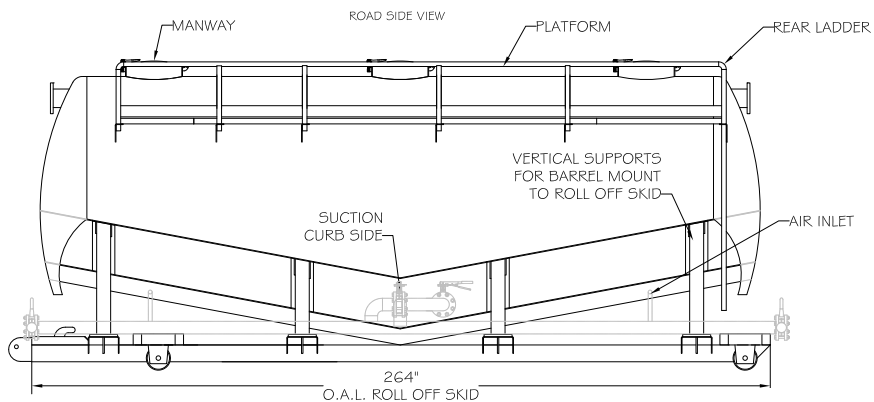
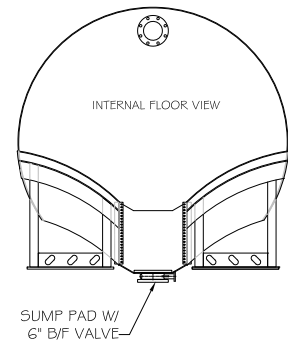
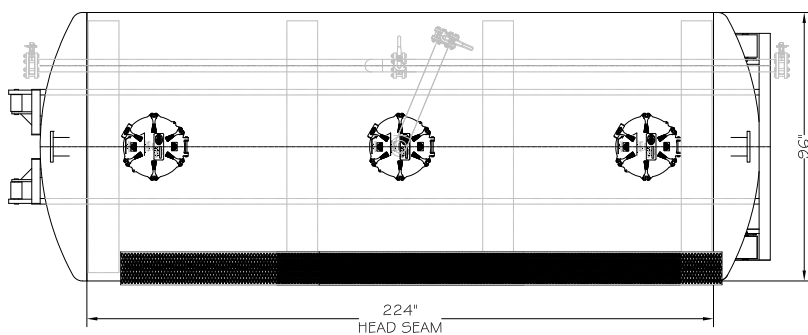

tanktrailer.sales@modernusa.com • www.dragonproductsltd.com • 877-231-8198

U.S. owned and operated for over 50 years. © Copyright 2017 Modern Group Inc. All rights reserved.